

Analog Metropolis

AM8022 ARP 2600 Noise Source

Project Notes V1.0

© Analog Metropolis 2009
Rob Keeble
Contact: info@emulatorarchive.com
Web Site: www.emulatorarchive.com

29 November 2009

1 Module Description

The AM8022 is a clone of the ARP 4022 Noise Source from the legendary ARP2600. The original design uses the traditional “transistor in avalanche mode” to generate white noise. This signal is then amplified and filtered (using LM301 Op Amps) to create the white and pink noise signals. The mix between the two types of noise can be manually adjusted via a front panel potentiometer (COLOUR), and the overall noise level adjusted with the LEVEL potentiometer.

The AM8022 module replicates exactly the original circuit, as all the components are still available. I have kept with the original LM301 Op Amp, as a high quality Op Amp is not really needed in a noise circuit.

I have added a simple Op Amp LED driver circuit to enable a LED to monitor the noise output level. The circuit has no trimmers and is easy to setup.

OUTPUTS AUDIO SIGNAL

POTS COLOUR
NOISE LEVEL

The REV01 board is the production board, with no errors or corrections.

2 Parts

All parts are available.

3 Front Panel Format

The AM8022 is designed to be used with a standard 3” FracRac panel, although other shapes and sizes can be used. I built my module with the Oakley Sound ARP 2600 Ring Modulator.

4 PCB, Pots and Power

The PCB is held to the front panel at 90 degrees by the use of two pot brackets. These brackets are centred at 1.6 inch apart. These brackets can be omitted if you wish; the pots will still hold the PCB in place. The PCB is designed to take 16mm Alpha PCB mounted pots, either round or splined shaft. Other makes of the same pin spacing and size will work.



The PCB is double sided with solder mask, component names are shown in the silk screen but not the component values. The size of the PCB is 80mmx100mm.

The module should be powered from a well regulated +15V and -15V power supply, current consumption is around 25mA. The power connector is the standard two ground MOTM/Oakley 4-pin Molex connector. One ground is for the circuit, the other is for the panel (PAD).

5 PCB Connections

The PCB has a number of connections designed for MTA 0.1" headers, so that the panel components can be connected to the PCB. I use headers and sockets to enable the board to be easily replaced, however you can solder wires straight to the PCB.

PCB Header Name	Pin #	What is it?	Where does it go?
LED1	Pin 1	Square PCB pad	Anode of LED
	Pin 2	Round PCB Pad	Cathode of LED
OUTPUTS	Pin 1	Signal Output	Jack socket OUT
	Pin 2	Signal Output	Not Used
PAD	Pin 1	Panel Earth	Jack socket earth bus

6 Building the Module

This module is simple to build. The recommended build order is:

- Resistors
- Inductors
- IC Sockets
- Capacitors
- Trimmers
- Connectors
- Transistors
- Pot Brackets and Potentiometers

Check all the electrolytic capacitors and transistors are fitted the right way round. Before fitting the IC's its worth connecting up the module to a power supply and checking that the power rail voltages are as expected at each IC socket, then power down, and fit the IC's ensuring correct orientation.

Power up and try out the noise source.

7 Parts Listing

Part Number	Value	Quantity	Comments
Capacitors			
All 5mm spacing			
C1, C2, C18, C19, C20, C21, C22, C23	100nF	8	Axial Ceramic
C3, C4	22uF 35V	2	Radial Electrolytic
C5	1uF	1	High quality Polyester
C6	3n3F	1	High quality Polyester
C7	10nF	1	High quality Polyester
C8	22nF	1	High quality Polyester
C9	50pF	1	Low-K Ceramic
C10	2nF	1	High quality Polyester
C11	20pF	1	Low-K Ceramic
C12, C14	10pF	2	Low-K Ceramic
C13	30pF	1	Low-K Ceramic
C15, C16	10uF 35V	2	Radial Electrolytic
C17	100pF	1	Ceramic
Resistors			
All 1% Metal Film			
R1	100K	1	
R2, R3	4M7	2	
R4	1K5	1	
R5	3K9	1	
R6	270K	1	
R7, R8	5M6	2	
R9	47K	1	
R10, R15	1K	2	
R11	22K	1	
R12	10K	1	
R13, R14	22R	2	
R16	See right	1	Value depends on LED used. 1K for normal LED, 10K for super bright
Potentiometers			
COLOUR, NLEVEL	100K LINEAR	1	Alpha 16mm
Semiconductors			
IC1, IC2, IC3, IC4	LM301	3	Single Op Amp
IC4	TL072	1	Dual Op Amp
T1	2N5172	1	Transistor
Passives			
L1, L2		2	Inductor
LED		1	3 or 5mm LED
Hardware			
OUTS		1	MTA 0.1" 2-pin header
POWER		1	MTA 0.156" 4-pin header

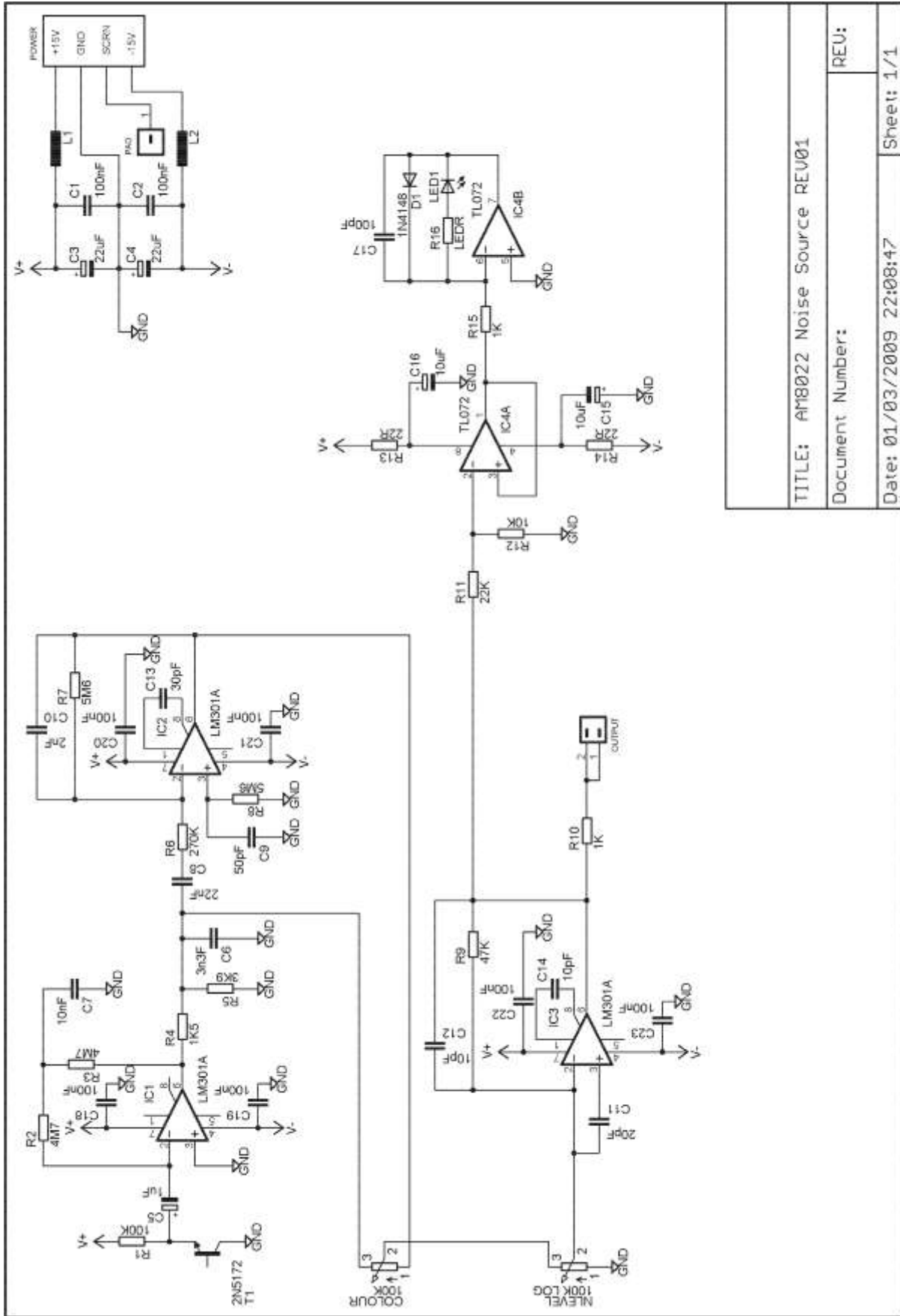

TITLE: AM8022 Noise Source REV01

Document Number:

REV:

Date: 01/03/2009 22:08:47

Sheet: 1/1